

# Alpha EdgeCrafter Operation Manual

Electric Polisher for straight & beveled edge.

CB-T4S(110v - 50/60Hz)



Please read this instruction manual thoroughly to ensure safety and correct use of machine.  
Keep this manual in a place where operators can access it easily, anytime when necessary.

## Introduction

Thank you for purchasing the Alpha EdgeCrafter, Electric Polisher for straight and beveled edge (CB-9SCE). Please read this instruction manual thoroughly for safety operation, machine handling, machine capabilities information and all other precautions before using the machine. Keep this manual in a place where operators can access it easily.

## About the symbols

Handling this machine incorrectly may cause an accident or injury. In this manual, safety notices are classified into “DANGER”, “WARNING”, and “CAUTION” according to the hazard level:



### DANGER

Death or serious personal injury are imminent when the operator neglects to follow suggested instructions.



### WARNING

There is a possibility of death or serious personal injury when the operator neglects to follow suggested instructions.



### CAUTION

There is a possibility of personal injury or property damage when the operator neglects to follow suggested instructions.

Note: Failing to observe CAUTION notices could result in death or serious personal injury in some situations. Be sure to read and observe the safety notices to ensure safety and correct use of the machine.

## Examples of the symbols

---



This symbol is followed by a DANGER, WARNING, or CAUTION notice, which depicts the suggested procedure or practice, and / or possible dangers or injuries.



The ○ symbol signifies prohibition. In or near this symbol, a prohibited action or motion is depicted. (The symbol on the left prohibits disassembling the machine).



The ● symbol signifies an order or instruction, Which is illustrated in the symbol. (The symbol on the left shows to unplug the power cord from the outlet.)

# CONTENTS

- Precautions for safe use of this machine.....5
  - 1. Operating environment.....5
  - 2. Clothing and protective equipment.....5
  - 3. Before use.....5
  - 4. Attaching tools.....6
  - 5. During use.....6
  - 6. After use.....7
  - 7. Precautions for using Alpha EdgeCrafter.....8
- Applications.....9
- Specifications.....9
- Part names.....9
- Standard and optional accessories.....10
- Wheels.....11
- Functions and instructions on using the EdgeCrafter.....11
  - One-touch removable unit.....11
  - Auxiliary casters (Ideal for monument applications).....12
  - Carriage assembly (Ideal for countertop applications).....12
  - Adjusting the angle of the chamfer.....13
  - Protective covers.....13
  - Mechanical stop and depth dial adjuster.....14
- Preparations before starting a job.....14
  - 1. Installing a ground fault circuit interrupter (GFCI).....14
  - 2. Grounding.....14
  - 3. Organize the work area for safe operation.....15
  - 4. Attaching a grinding/polishing wheel.....15

5. Checking the power switch.....	16
6. Checking the power outlet.....	16
7. Making test runs.....	16
How to operate.....	16
1. Using the EdgeCrafter for countertop applications.....	17
1-1. Set-up of the guide rail.....	17
1-2. Installation of the EdgeCrafter onto the guide rail.....	17
2. Using the EdgeCrafter for monument applications.....	18
3. How to grind.....	19
4. Using the depth dial adjuster to maintain a constant bevel / chamfer width.....	19
5. Adjusting the chamfer angle.....	20
6. Protective covers.....	20
Maintenance and inspection.....	21
1. Rubber gloves and waterproof safety boots.....	21
2. Checking the attaching screws.....	21
3. Checking the carbon brushes.....	21
4. Handling the motor.....	21
5. Checking the one-touch joint assembly.....	22
6. Checking the guides.....	22
Troubleshooting.....	23
Schematic.....	24
Parts list.....	25
Declaration by the manufacturer.....	27

## Precautions for safe use of this machine

Correct operation and regular maintenance are essential for safe operation of this machine. Be sure to read safety notices in this manual carefully before using or servicing the machine.

### 1. Operating environment



#### WARNING

- **Restrict access to the workshop.**  
Do not permit anybody but the operator to have access in the workshop. In particular, be sure to keep children away from the workshop.
- **Be careful of fire or explosions.**  
Never use this machine near ignitable or explosive materials including gasoline, combustible gases, or inflammable adhesives.  
Otherwise, sparks generated by commutation or switching may cause fire or explosion.



#### CAUTION

- **Keep the work area in order.**  
Take particular care by keeping the workarea in order.  
Leaving the work bench or work area untidy could cause cloth or material to be caught at the end of tools or machine, therefore can be dropped, resulting in a dangerous situation. Use the machine under adequate lighting.

### 2. Clothing and Protective equipment



#### WARNING

- **Wear personal safety clothing and equipment.**  
Be sure to wear all personal safety equipment including protective glasses, waterproof safety boots, earplugs, and rubber gloves. If necessary, wear a dustproof mask in dusty areas. Inhaling dust can damage the throat, lungs and respiratory system.



#### CAUTION

- **Wear appropriate clothing**  
Do not wear loose clothing.  
They can be caught in the rotating part of the machine.

### 3. Before use



#### WARNING

- **Supply the specified voltage**  
Supply the voltage specified on the nameplate of the machine.  
Otherwise, damage could result to the machine, or risk of personal injury.
- **Do not let water into the motor.**  
Water inside the machine will weaken the electrical insulation of the motor and may result in electric shock.
- **Take measures against electric shock.**  
Be sure to install a GFCI to the power source to prevent electric shock.



## CAUTION

- **Use the machine only for its designated applications.**

Do not use the machine for any purpose other than those specified in this manual.

Do not use the machine for grinding or polishing metal and wood workpieces.

This machine is specialized for processing of glass and natural stone.

## 4. Attaching tools



## WARNING

- **Prevent accidental start-up.**

Be sure to unplug the power cord from the outlet before attaching or removing polishing wheels.

Starting the motor accidentally may cause bodily injury.

## 5. During use



## DANGER

- **Do not touch rotating parts.**

Never access or touch the rotating wheel of the machine with your hands or body during operation.



## WARNING

- **Secure work piece.**

Use clamps to securely fix a workpiece onto the bench.

A loose workpiece may drop and cause bodily injury.

- **Do not operate the machine from an awkward position.**

Ensure a secure footing and stable body position before and during operation the machine.

Operating the machine in an awkward position will increase human fatigue.

- **Prevent accidental start-up.**

Turn off the power switch before plugging the power cord into the outlet.

Turn off the power switch and unplug the power cord when power failure occurs.

Do not carry the machine while the power cord is connected to the outlet.

Starting the motor accidentally may cause bodily injury

- **Do not overload the machine.**

Never operate the machine at an output which exceeds the rated voltage specified on the plate.

- **Operate the machine with attention.**

Do not use the machine when you cannot concentrate or make appropriate decisions (when tired, or under the influence of drugs or alcohol)



## CAUTION

- **Use the machine after you have appropriate training and knowledge about it.**  
Never permit an untrained person or a child to use the machine.
- **Handle the machine with care.**  
If you accidentally drop, do not use the machine until checking that it is not cracked, deformed, or in any way damaged.  
Do not block the ventilation window to avoid motor burnout.

## 6. After use



## WARNING

- **Use specified parts**  
Use specified genuine replacement parts when servicing the machine



## CAUTION

- **Conduct adequate maintenance and inspection.**  
Blow dust from inside the motor.  
Always clean and maintain the power cord to prevent damage due to oils or grease.
- **Unplug the power cord when not using the machine.**  
Be sure to unplug the power cord from the outlet before maintenance, change parts, inspection, or cleaning.
- **Keep the machine in a safe place.**  
After using the machine, remove any dust or dirt from it and store it in a dry, safe place.  
Do not store the machine in areas:
  - where children can reach the machine or it can be easily tampered with;
  - where temperature and humidity fluctuate suddenly;
  - where the machine is exposed in rain and high humidity;
  - where the machine is exposed in direct sunlight.
- **Handle the cord properly.**  
Do not move the machine without unplugging the power cord, or pull the power cord out of the outlet.  
By doing so may cause disconnection or short-circuit.  
Avoid contact with heat, oil, or sharp objects.

## ATTENTION

Observe the laws and regulations of noise levels in your area.  
Please observe local laws and regulations regarding noise control in order to avoid disturbing surrounding areas.  
Install a soundproof wall if required to comply with the local laws and regulations.

## Precautions for using the Alpha EdgeCrafter.

In addition to the general safety notices described on the preceding pages, please read and observe the following safety notices before using the machine.



### WARNING

- **Use protective covers.**  
Be sure to attach the protective cover and use it during operation.  
The protective cover will protect the operator if the wheel breaks.
- **Do not leave the machine unattended while running.**  
Do not leave the machine unattended on the workbench or workshop while it is running.
- **If you accidentally drop the machine, do not use the machine until checking that it is not cracked, deformed, or damaged.**  
Cracks, deformation, or damage of the machine and/or wheel may cause bodily injury.



### CAUTION

- **Follow the procedures specified in the instruction manual correctly to attach a wheel or an accessory to the machine.**  
If accessories are not correctly attached, they will scatter or fall off and may cause bodily injury.
- **When for the 1st time a new wheel is attached and machine is turned on, observe any suspicious abnormal noises.**
- **Conduct a test run.**  
Wait until the machine reaches operating rotation speed, and check that there are no abnormal sounds or vibrations during idling. Refer to page 16 (7. Making test run)  
Operations without conducting a test run could cause bodily injury.
- **Be careful of your surroundings when working in high places.**  
When working in high places, make sure there are no people below.  
Be careful not to catch the power cord on anything.  
Be careful not to drop the machine or any materials. It may cause an accident.
- **Install the power cord and the water hose to avoid interference with working area.**  
Make sure the power cord and the water hose do not interfere with working area.

## Applications

Grinding, sanding and polishing the straight edge of glass, engineered stone, porcelain ceramic and natural stone.

Grinding, sanding and polishing the bevel edge of glass, engineered stone, porcelain ceramic and natural stone.

## Specifications

Working power supply:	Single-phase AC, 50/60 Hz
Voltage:	110v
Motor:	Single-phase, series commutator motor
No load:	4,000 r.p.m.
Continuous operation:	30 minutes
Weight:	6.8 kg
Cord:	7m vinyl insulated three-conductor power cord with a grounding clip

## Part names

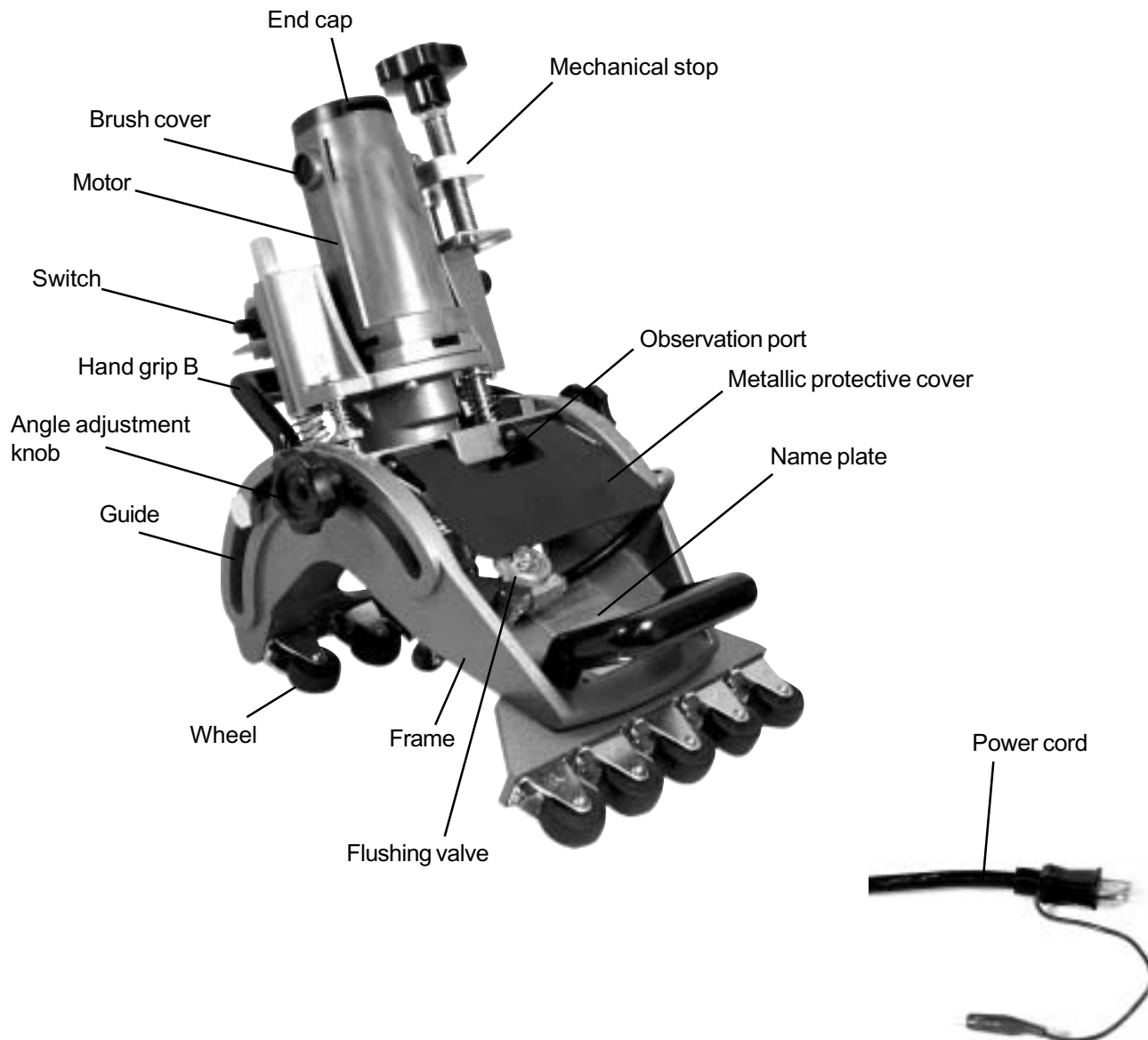

**Standard accessories:**



Translucent splash guard



Translucent side splash guard



Guide springs for hand pressure



220V - 50/60Hz GFCI



Rubber gloves

Auxiliary guiding wheels with mounting plates



Auxiliary installation screws M4 x 16

14mm wrench



EdgeCrafter CD

---

**Optional accessories (Ideal for countertop applications).**



Carriage assembly

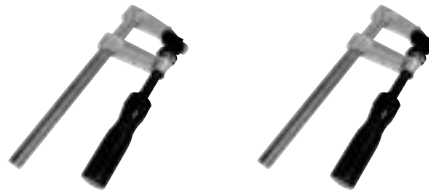

Clamps



Guide rail  
(Available in 4' (1.2m), 6.6' (2m), 10' (3m))

## Wheels:

### Wheels for Alpha EdgeCrafter

For Marble:	CBR-200, CBR-400, CBR-800, CBFP-RF, CBFP-RS
For Granite:	CBD0060M, CBD0200M, CBD0300R, CBD0800R, CBD1500R, CBFP-SS, CBFP-NP, CBFP-RO
For Engineered Stone:	CBD0060M, CBD0200M, CBD0200ES, CBD0500ES, CBD1000ES, CBD2000ES, CBD3000ES.
For Thin Glass:	CBG0220N, CBG0280N, CBFP-GX
For Thick Glass: 3/16" (5mm) & up	CBG0140M, CBD0200M, CBD0200R, CBD0500R, CBD1000R, CBD2000R, CBD3000R, CBFP-GX

## Functions and instructions on using the EdgeCrafter

One-touch removable unit



### WARNING

Before attaching or removing wheels, be sure to unplug the power cord from the outlet.



Unplug the power cord from the outlet.

### [How to attach wheels]

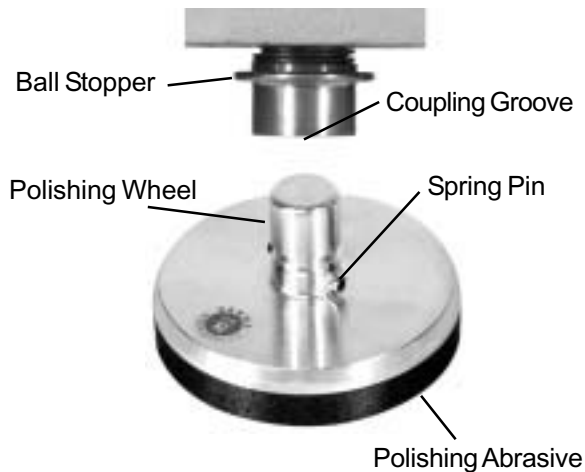

Figure 3

The one-touch attachment allows you to exchange wheels easily, as needed.

1. Grab the ball stopper, push it back and hold it.
2. Align the spring pin on the wheel boss with the coupling groove. Then, push the wheel straight in.
3. When the wheel is fully inserted, release the ball stopper.
4. Make sure that the wheel is securely attached and will not come off or rattle.
5. To remove the wheel, pull back the ball stopper and remove the wheel. (See figure 3)

---

## Auxiliary casters (Ideal for monument applications)

---

The use of auxiliary guiding wheels allow you to accurately chamfer each edge of monument, just by moving the machine slowly along the edge.

1. Remove the four outermost guiding wheels from both sides, as shown in Figure 4.
2. As shown in Figure 5, attach the four auxiliary guiding plates in the place where original guiding wheels were removed from. Reattach the guiding wheels you previously removed to the ends of the auxiliary guiding plates.
3. In this situation the surface will be the guide along the edge, riding on top with high precision, as shown in Figure 6. To make this possible you need to clamp on L shape bar on top of your work piece. This L shape bar will be guiding the EdgeCrafter along the edge of your work piece. The surface of your work piece will be guiding the EdgeCrafter horizontally.



Figure - 4

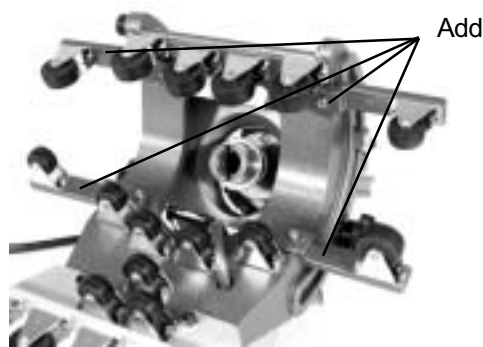

Figure - 5

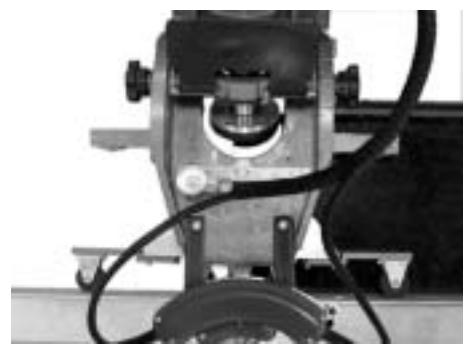

Figure - 6

---

## Carriage Assembly (Ideal for counter top applications)

---

The use of carriage assembly allows you to accurately chamfer each edge of glass, natural stone and/or engineered stone, just by moving the machine slowly along the guide rail.

1. Remove all guiding wheels except the ones in the center, as shown in Figure-7
2. As shown in Figure-8, attach the carriage assembly on top of the frame. The carriage assembly should be mounted between the frame and handle A.
3. In this situation the guide rail will guide the EdgeCrafter along the edge with high precision, as shown in Figure - 8.



Figure - 4



Figure - 7

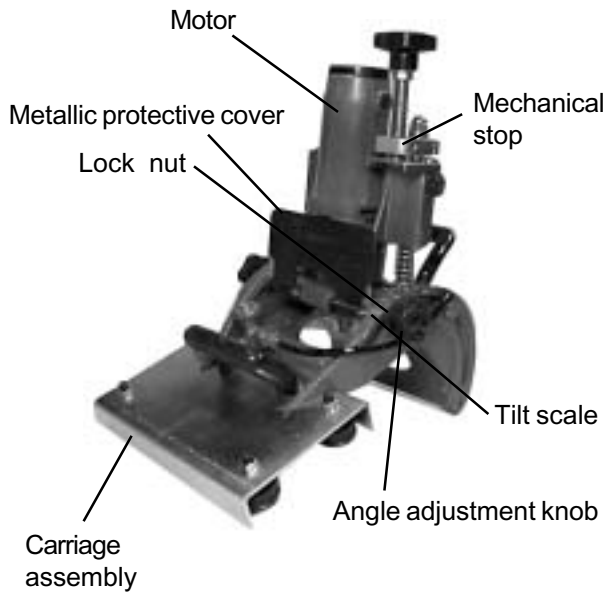

Figure - 8

---

## Adjusting the angle of the chamfer

---



**Figure 9**

The tilt angle can be adjusted from 0 to 90 degrees. The marks on the scale are in 5 degrees increments.

1. Loosen the knobs on both sides of the guides.
2. Set the grinding angle, using the tilt scale on the top of the left guide and the pointer attached to the head table.
3. Tighten the knobs on both sides of the guide securely.

If the machine will be used at 45 degrees, the knobs can be firmly locked by using the lock nuts, to prevent any change in angle.

---

## Protective covers

---

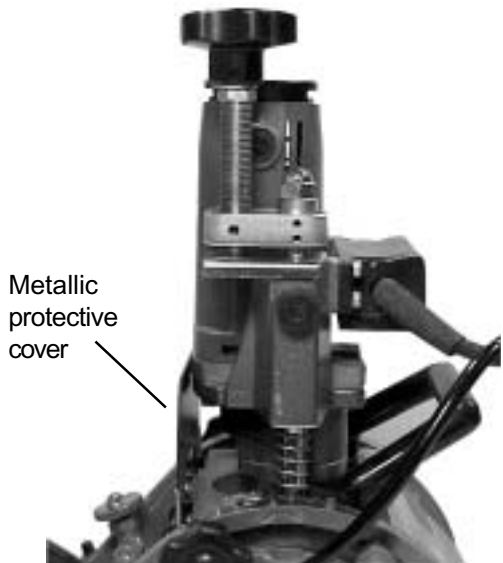

**Figure 10**

The metallic protective cover protects the operator if the wheel breaks and prevents the water from splashing. To exchange wheels easily, lay the machine on its side.

For ease of use, EdgeCrafter is equipped with a top and side translucent protective covers.

Top translucent protective cover uses a magnetic strip to attach onto metallic protective cover.

Side translucent protective covers use Velcro® attachments to attach onto both sides of the frame.



Caution

Always wear safety glasses.



Figure 11

### **Mechanical Stop**

The wheel pressure applied onto the stone can be adjusted by rotating the mechanical stop knob.

1. To increase the pressure, rotate the mechanical stop knob in a clockwise direction. The abrasive should get closer to the edge of your material.
2. To release the pressure, rotate the mechanical stop knob in a counter clockwise direction. The abrasive should get farther from the edge of your material.

### **Using the depth dial adjuster and mechanical stop to maintain a constant bevel/chamfer width**

The abrasive pressure and depth of grind/polish applied onto the stone can be adjusted by using the mechanical stop together with depth adjuster dial. The depth adjuster dial is a safety feature designed to avoid accidental over grinding.

1. Rotate the depth adjuster dial in a counter clockwise direction. The depth adjuster dial should move away from the frame. (See figure 11)
2. Rotate the mechanical stop knob in a clockwise direction. The abrasive should get closer the edge of your material, eventually touching it.
3. Proceed grinding until desired depth/width of chamfer is achieved.
4. Rotate the depth adjuster dial in a counter clockwise direction. The depth adjuster dial should move closer to the frame. This procedure will set the depth of grind/width of chamfer for future grinding/polishing operations. Each full turn of the dial will increase the face width by 2 mm.

### **Preparations before starting a job**

Before using the machine, be sure to complete the following preparations.

- 1. Installing a ground fault circuit interrupter (GFCI).**  
To prevent electrical shocks, be sure to install the provided ground fault circuit interrupter (GFCI) between the main power supply and the cord of the machine.
- 2. Grounding**  
The machine should be thoroughly grounded by attaching the grounding clip of the power cord to an existing ground.

**Note to the user:** A GFCI must be used when this machine is used anywhere in a damp environment, or when it is used with a highly conductive liquid like water, or when it is used on metal plates, steel frames or platens.



## DANGER

Before using the machine, be sure to ground it. Never connect the ground lead to a gas pipe. This is very dangerous.



Be sure to connect the ground lead.

### 3. Organize the work area for safe operation

Before beginning operations, make sure that the work area conditions are well organized for safe operation of EdgeCrafter.



## WARNING

Before using the machine, check the following. Items 1 - 5

#### a. Rubber gloves and waterproof safety boots.

Be sure to wear rubber gloves and waterproof safety boots. If they are damaged, cracked or have any holes in them, replace them. Otherwise, you may receive an electrical shock.

#### b. Check the working voltage.

Be sure the voltage specified on the nameplate is the voltage available at the outlet. If the machine is used with higher voltage than specified, the motor will burn out. This machine cannot be used with a direct voltage source or with a portable generator. Any attempts to do so may damage the machine or cause an accident.

#### c. Inspect your polishing wheels.

Never use damaged, cracked or chipped polishing wheels.

### 4. Attaching a grinding/polishing wheel

1. Use your fingers to push the ball stopper back and hold it, as shown in Figure - 12.
2. Align the spring pin of the wheel with the coupling groove. Then, push the wheel straight in.
3. When the wheel is fully inserted, release the ball stopper.
4. Make sure that the wheel is securely installed and will not come off or rattle.
5. To remove the wheel, pull back the ball stopper and remove the wheel.

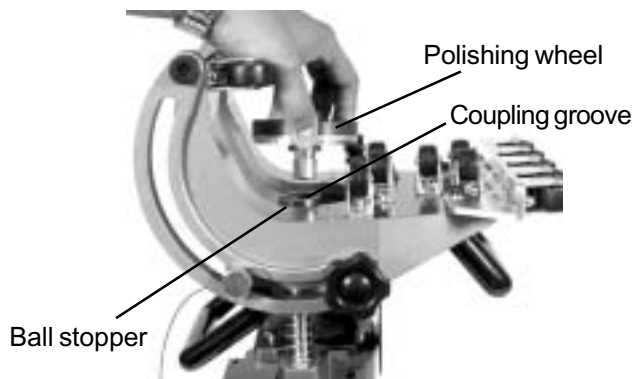

Figure 12



Figure 13

## 5. Checking the power switch

If you plug in the power cord without realizing that the switch is **ON**, the EdgeCrafter will not start due to the kill switch feature.

When the switch lever (see “Part names”) is flipped toward the **ON** position, the EdgeCrafter is ready to be turned **ON**.

When the switch lever is flipped toward the **OFF** position, the EdgeCrafter is completely turned **OFF**.

Make sure the switch lever is flipped toward the **OFF** position before plugging in the power cord. (See figure 14)

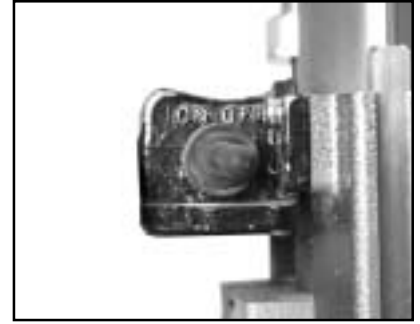

Figure 14

## 6. Checking the power outlet

If the power cord plug is loose or is easily pulled out of the power outlet, then the outlet should be replaced. For such task, consult your electrician.

If the power outlet is used continuously, it may overheat and cause accidents.

## 7. Making test runs



### CAUTION

- Before turning the switch **ON**, make sure that the rotating parts are not touching anything. If the switch is turned **ON** while they are in contact with anything else, the wheel may break and it may cause injuries.
- When a new wheel is attached and the switch is first turned on, keep your body well away from the exposed sides of the wheel for a moment until the machine reaches full speed.

It is very dangerous to perform grinding operations using damaged, cracked or chipped wheels. Before starting grinding operations, keep the wheel away from anyone nearby. Be sure to make a few test runs, to check whether there are any abnormalities.

Test run duration:

When replacing a wheel.....At least 3 minutes

When starting operations each day.....At least 1 minute

## How to operate



### WARNING

- If grinding operations are interrupted due to replacing a wheel or when you are through with a particular operation, be sure to turn **OFF** the switch.
- During operation, be sure to wear safety glasses.
- If water gets in the motor, it may shock the operator or damage the machine. When halting an operation or replacing a wheel, put the machine in a safe place where water will not be splashed on it.
- Be sure to look through the observation port when checking the grinding condition, the rotation of wheel or the position of the wheel during operation..(see fig. - 16)



Remove the plug from the outlet.



---

## 1. Using the EdgeCrafter for countertop applications

---

### 1-1 Setup of the guide rail

Your guide rail should extend a minimum of 6" (15.5 cm) past both sides of the stone. Make sure that you select the correct size guide rail for your work piece. See figure 17.

- a. Set your work piece on the work bench and secure it using appropriate clamps. Take care to leave enough overhang for the guide rail clamps to clear the work bench. Please see tech note for guide rail set up with Alpha VHS-5C Vacuum Hold Down System. (See figure 15)



Figure 15

- b. Set your guide rail 2 3/4" (7 cm) away from the edge of aluminum guide rail plate as parallel as possible with the edge that has to be polished. Check your layout to ensure that there is 2 3/4" (7 cm) between the guide rail plate and the edge of your work piece. (See figure 16)

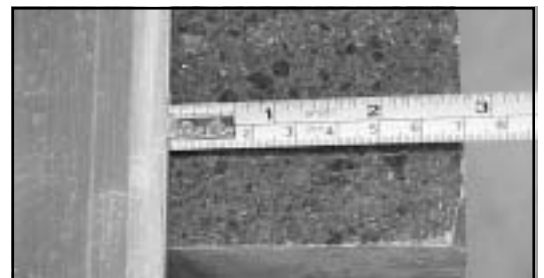

Figure 16

- c. Insert the guide rail clamps into the slots located underneath of the guide rail. Proceed tightening the clamps until the guide rail is locked into position. Re-check your layout to ensure there was no accidental movement and re-adjust if necessary. (See figure 17)



Figure 17

### 1-2 Installation of the EdgeCrafter onto the guide rail

- a. Align the EdgeCrafter Carriage Assembly with end of the guide rail and carefully guide the carriage wheels onto the rail. The fit should be tight at first but once all four wheels are on the rail, movement should be smooth. (See figure 18)

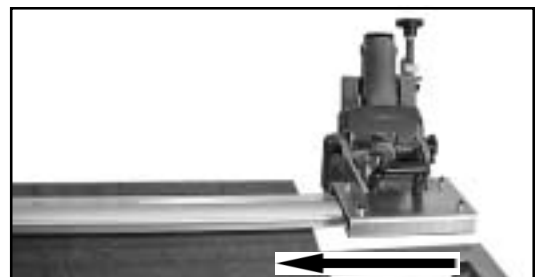

Figure 18

---

## 2. Using the EdgeCrafter for monument applications

---

### 2-1 Move the Alpha EdgeCrafter along the stone workpiece

The wheel in Alpha EdgeCrafter should touch the edge of the stone workpiece without running the motor. In this position, all guiding wheels should be in contact with the stone or glass surface. When the machine is moved beyond the edge of the workpiece, be careful not to drop it. Polishing should not pass completely over the stone workpiece. It may pass over only half way.

To check the position of polishing wheel, be sure to look at it through the observation port.

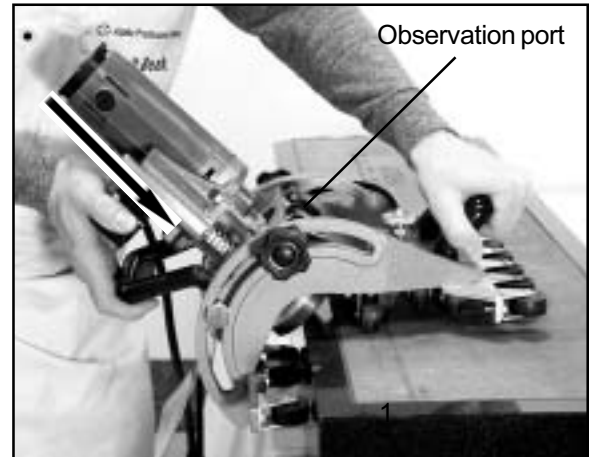

Figure 19

### 2-2 How to apply pressure by hand.

Using your right hand, grip handle B and apply pressure onto the machine.

When doing this, the depth adjusting dial should move to its upper limit touching the frame. (See figure 19 & 20)

Can you feel the reaction of the spring?

### 2-3 Adjusting the water volume.

Connect a hose to the machine hose and to a water tap. Turn **ON** the water at the main tap. Adjust the volume of water by rotating the valve located on the frame.

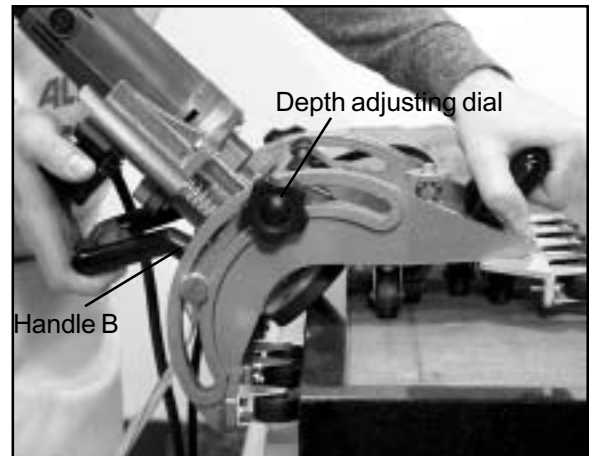

Figure 20

---

### 3. How to grind

---

**3-1** Make sure the water is flowing. Move the chamfer machine along the stone workpiece to grind it. Adjust the water flow, traveling speed and pressure while grinding.

**3-2** Switch operation

When the switch lever (see “Part names”) is tilted toward the ON label, the machine is turned on. When it is tilted toward the OFF label, the machine is turned off.

**3-3** How to handle the wheels

After switching the machine ON, and the motor has reached its constant rpm’s, begin grinding.

When the wheel first comes into contact with the workpiece, make contact slowly.

Do not apply more pressure onto the EdgeCrafter than is required. Such action may actually damage the wheel, reduce its working efficiency and shorten the machine’s service life.

According to the material used, the following sequence of wheel are recommended:

**For Marble:** CBR-200, CBR-400, CBR-800, CBFP-RF, CBFP-RS

**For Granite:** CBD0060M, CBD0200M, CBD0300R, CBD0800R, CBD1500R, CBFP-SS, CBFP-NP, CBFP-RO

**For Engineered Stone:** CBD0060M, CBD0200ES, CBD0200ES, CBD0500ES, CBD1000ES, CBD2000ES, CBD3000ES.

**For Thin Glass:** CBG0220N, CBG0280N, CBFP-GX

**For Thick Glass:** CBG0140M, CBD0200M, CBD0200R, CBD0500R, CBD1000R, 1/4” (5mm) & up CBD2000R, CBD3000R, CBFP-GX

**3-4** Precautions immediately after use:

After the job is completed, turn off the switch. After the wheel stops rotating completely, put the machine in a safe place.

If your hand is released off the machine before the wheel stops rotating, it may cause an accident. Wait until the machine stops running.

---

### 4. Using the depth adjuster to maintain a constant bevel / chamfer width

---

When making a wide chamfer on the edge of a workpiece, use the depth adjuster to keep the width of the face constant.

**4-1** Rotate the dial to raise the depth adjuster.

**4-2** Push on the machine until the wheel is in contact with workpiece.

This position is the reference position.

**4-3** To set the chamfer width, rotate the dial to raise the depth adjuster.

Each full turn of the dial will increase the face width by about 5/64” (2mm). (See figure 21)

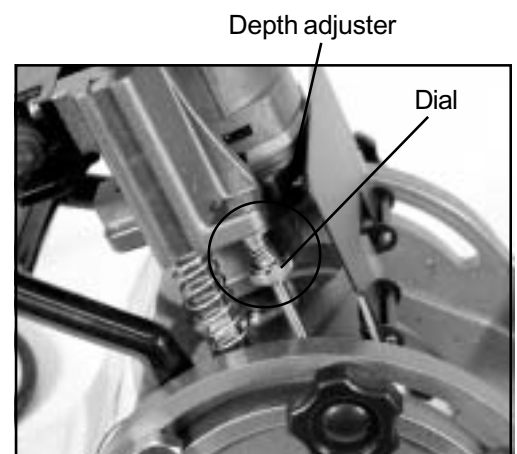

Figure 21

Bevel angle	0	10	20	30	40	50	60	70	80	90
The full chamfer width for one turn of the dial (mm)	-	5.8	3.1	2.3	2.03	2.03	2.3	3.1	5.8	-

## 5. Adjusting the chamfer angle

The chamfer angle can be adjusted from 0 degrees to 90 degrees (side).

### 5-1 How to change the angle

1. Loosen the knobs on both sides of the guides.
2. Set the angle you want by aligning the tilt scale on top of the guides with the pointer attached to the head table.  
Each graduation is equal to 5 degrees.
3. Tighten the knobs on both sides of the guide securely. (See figure 22)

If the machine will be used at 45 degrees, the left knob will lock firmly in its position. This is possible because the frame has a ridge casted on the left side to prevent any accidental change in angle.

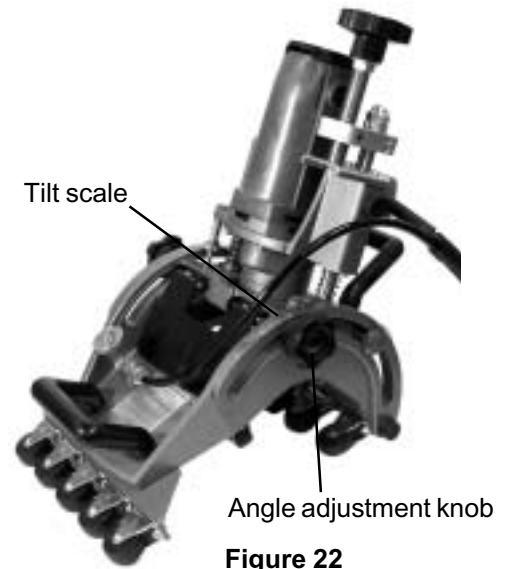

Figure 22

## 6. Protective covers

Both protective covers protect the operator if the wheel breaks. It also prevents the water from accidentally being splashed everywhere. (See figure 23)

### 6-1 The metallic protective cover

The metallic protective cover should be used primarily during rough grinding applications especially during calibration process.

### 6-2 The translucent protective covers

The top translucent protective cover should be used during polishing applications where monitoring of polishing process is essential. The side translucent protective covers should be used during polishing applications to avoid splashing water sideways.

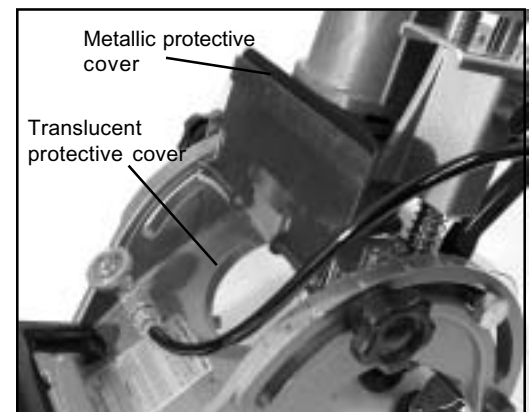

Figure 23



### CAUTION

Even when the protective cover is used, be sure to wear safety glasses.

## Maintenance and inspection



### WARNING

Be sure to unplug the cord from the outlet. Otherwise, the machine may start abruptly and it may cause an accident.



Unplug the power cord from the outlet.

### 1. Rubber gloves and waterproof safety boots

Always be sure to wear rubber gloves and waterproof safety boots. If they are worn, cracked or have any holes in them, replace them.

### 2. Checking the attaching screws

Before starting any operation, if any screws are loose.

If the machine is used with loose screws, it is dangerous. Be sure to retighten them.

### 3. Checking the carbon brushes

Carbon brushes are used inside the motor and will wear out over time.

If a carbon brush is worn too much, it may cause the motor to malfunction or fail. If the length of the carbon brush reaches the wear limit  $5/32$ " (4 mm), replace it.

Keep the carbon brush clean, so that it can slide freely in the brush holder.

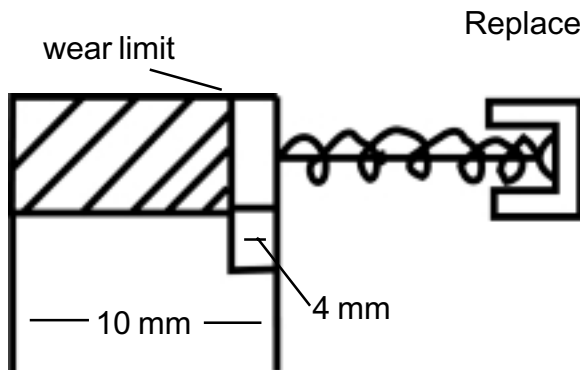

Replacement procedure

When the brush cover (see "part names") is removed using a flat screwdriver, the carbon brush can be removed.



### CAUTION

When replacing the carbon brush with a new one, be sure to use only an MG-1003 carbon brush made by Sanko (or Mitachi).

### 4. Handling the motor

The motor windings are the heart of this machine. Pay special attention not to damage the windings and not to expose them to oil or water.



### CAUTION

If dust or dirt settles in the motor, it may cause it to malfunction.

After 50 hours operation, run the motor with no load and blow dry air in the End Cap (see "part names").

This is effective for removing dust or dirt.

## 5. Checking the one-touch joint assembly

---

Attach a wheel and make sure it does not rattle. If locking balls fall out due to wear or if the wheel shakes or vibrates when turned by hand, replace it.

### Replacement procedure

1. Put the included wrench on the base of the spindle. With a wheel attached to the one-touch ball stopper section, push hard on the wrench in a clockwise direction as seen from the end of the shaft attachment. (See figure 24 & 25)



### CAUTION

When removing the one-touch release section while holding onto the wheel, the wheel may cut your bare hands. Therefore, be sure to wear thick gloves when holding the wheel.

2. If the ball does not move smoothly, remove any dust in that area. Grease the hole where the ball is or apply one or two drops of oil into the hole.

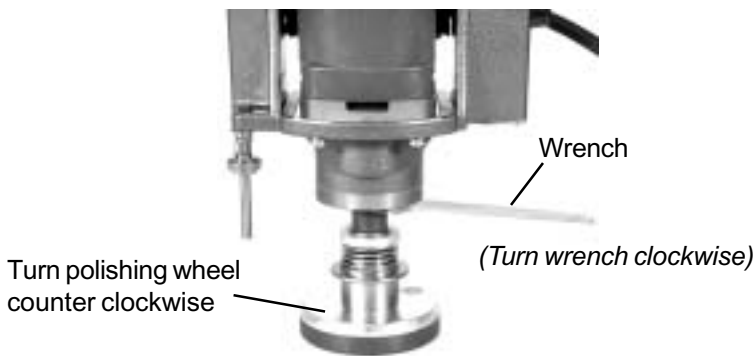

Figure 24

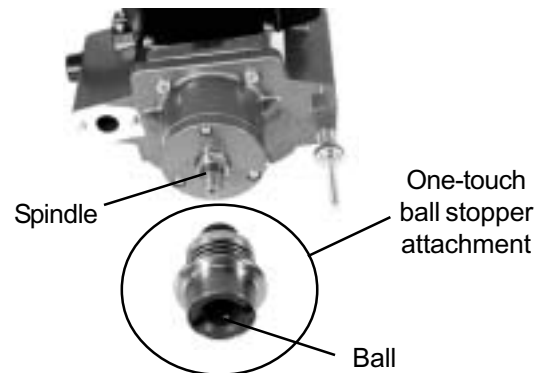

Figure 25

## 6. Checking the guides (see “part names”)

---

If the chamfer angle cannot be adjusted smoothly, remove any dust from the guide slots on the both sides of the frame, and apply a light coating of grease or oil.

## Troubleshooting

If the machine does not operate normally, do not try to repair it by yourself. Contact your dealer or Alpha Professional Tools.



### DANGER

If this machine is disassembled, there may be a possibility of electrical shocks.  
Do not disassemble this machine.



Never disassemble the machine.

The machine you purchase may have a somewhat different appearance from the one used in the figures in this manual.

### Limited Warranty of Alpha EdgeCrafter

Alpha Professional Tools warrants this product against defects in material and workmanship for a period of 90 days from the date of original retail purchase (proof of purchase required). If Alpha Professional Tools receives notice of such defects during the warranty period. Our obligation assumed under this warranty is limited to the repair or replacement of parts, without charge. This warranty does not apply to tool accessories.

For Warranty Claims: Send complete tool with all your information and details of the problem to the below address, transportation prepaid. Do not send tool accessories.



250 Braen Avenue, Wyckoff, NJ 07481 • 1-800-648-7229 • Fax: 201-447-1128  
[www.Alpha-Tools.com](http://www.Alpha-Tools.com)

# Schematic

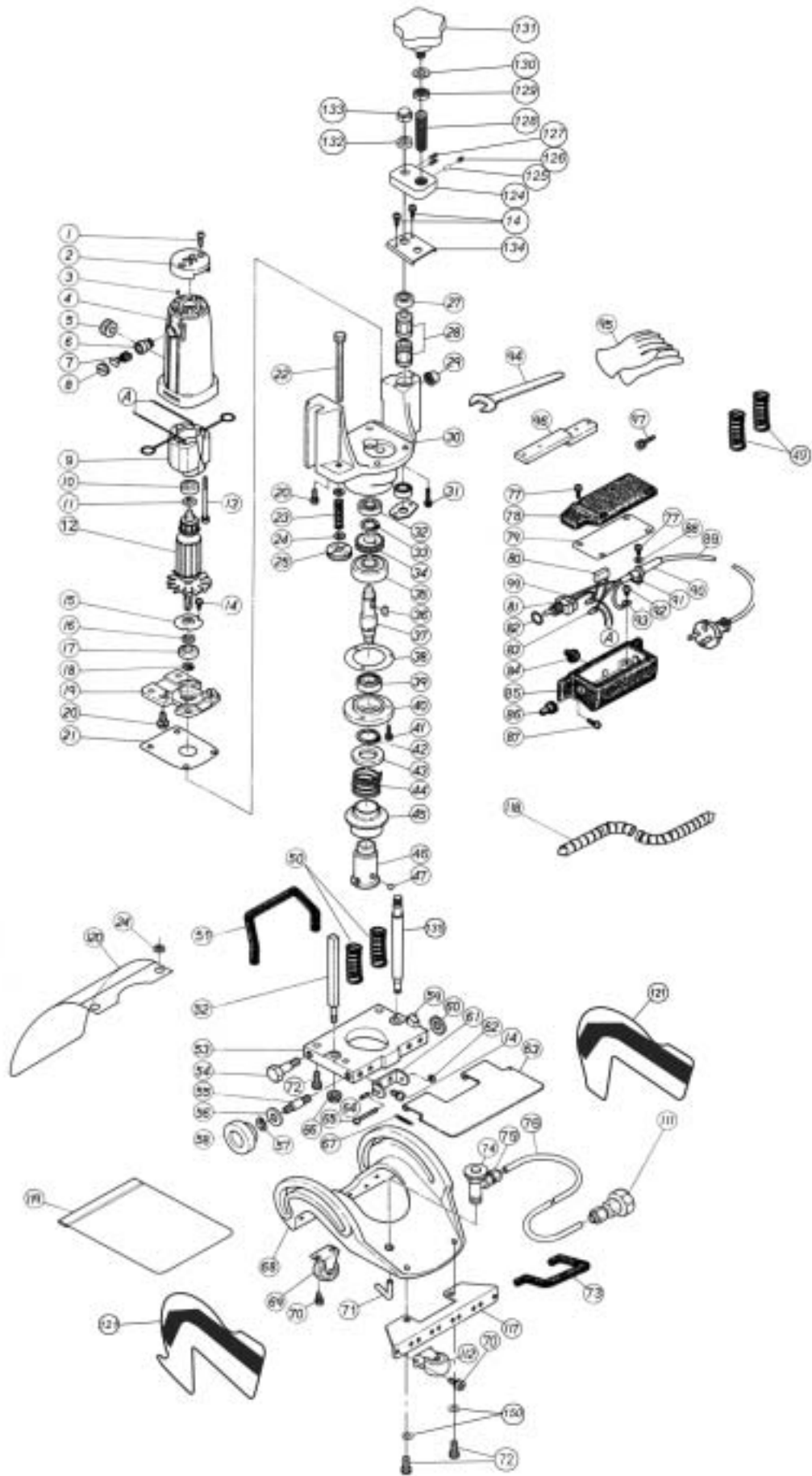

Part No.	Description		
01	Screw for end cap M5x16	53	Head table
02	End cap	54	Guide bolt
03	Set screw M4x6	55	Grip shaft
04	Body	56	Washer for grip
05	Rubber bush	57	Spring Washer
06	Carbon holder	58	Knob nut
07	Carbon brush (2pcs/set)	59	Arrow mark plate
08	Holder cap	60	Lock washer
09	Field coil 220V.	61	Falcrum plate for cover
10	Bearing 608VV	62	Hex. headed Nut M3
11	Dust plate 608	63	Protector
12	Armature 220V.	64	Hook pin
13	Screw for field coil SWRM3 M4X65	65	Screw M3x45
14	Screw M4x10	66	Nut M10
15	Cap for bearing	67	Protector spring
16	Felt packing	68	Frame
17	Bearing 629VV	69	Caster wheel R-25
18	C-Ring 9mm	70	Hex. Head screw M4x10
19	Center Bracket	71	Copper pipe
20	Screw M5-20	72	Cap screw M6x20
21	Bracket gasket	73	Grip A (left hand)
22	Hex. Head screw M6x75	74	Water valve
23	Stopper spring	75	Hose stopper band
24	Washer M6	76	Water hose
25	Stopper nut	77	Screw M4x12
26	Oil seal stopper	78	Box plate
27	Oil seal 13x25x7	79	Switch case gasket
28	Bearing LB13NYDD	80	Condenser
29	Rubber Stand	81	Switch
30	Head Frame	82	O-Ring
31	Screw M5x30	83	Flat terminal
32	Bearing 629 DDW	84	Rubber bush (switch box)
33	C-Ring 15mm	85	Switch box
34	Helical gear	86	Switch rubber cap
35	Bearing 6302VV	87	Screw 5x15
36	Key 5x5x12	88	Washer M4
37	Spindle shaft	89	Cable with plug
38	Head cap gasket	90	Cord bundle
39	Oil seal 18x30x8	91	Cord bundle stopper
40	Head cap	92	Screw M4x8
41	Screw M4x16	93	Ground terminal
42	C-Ring 20mm	94	Wrench 14MM
43	Stop spring collar	95	Rubber gloves
44	Cup ring sping	96	Guiding Plate
45	Ball stopper	97	Hex. Head screw M4x16
46	Cup ring type-C	98	Spring washer M6
47	Steel ball 3/16	99	Wire Terminal
48	N/A	108	Mini-valve S
49	Soft guide spring set	109	Valve joint
50	Hard guide spring set	111	Water hose joint w/nut
51	Grip B (Right hand)	112	Caster wheel R-32
52	Square bar	117	L-sub-wheel setting plate
		118	Spiral bandle tube
		119	Water protect sheet A

<b>Part No.</b>	<b>Description (continued)</b>
120	Water protect sheet B
121	Side splash guards (left & right)
124	Lever base
125	Nylon patch
126	Set screw M5x6
127	Set screw M4x10
128	Push screw
129	Slim nut M10
130	Spring washer M10
131	Knob BTK60x20
132	Spacer
133	R nut M10
134	Stopper plate
150	Flat washer M6

# DECLARATION BY THE MANUFACTURER

(amended directive 89/392/EEC - Annex II A)

Name of manufacturer: Alpha Professional Tools

Address of Manufacturer: 250 Braen Avenue  
Wyckoff, New Jersey 07481  
USA

Herewith declares that:

ELECTRIC TOOL: "EdgeCrafter"

Make: Alpha Professional Tools

Type: CB-9SCE

Serial No: between                      and                      inclusive.

- does comply with the provisions of the "Machinery" Directive (Directive 89/392/EEC amended by Council directive 91/368/EEC, 93/44/EEC and 93/68/EEC)

And furthermore declares that:

- The following (parts/clauses of) harmonized standards have been applied:

On request of Alpha Professional Tools, the compliance of the model with the requirements of the EC Machinery Directive was established by AIB-VINCOTTE INTER, Avenue A. Drouart 27-29, B-1160, Brussels, Belgium (notified body under the number 26 for machinery Listed in annex IV of the EC Machinery Directive), acting here as competent body.

Wyckoff, New Jersey USA

September. / . 1999

DIRECTOR.

Alpha Professional Tools